

OZEFRIDGE

Oze fridge Refrigeration Systems.

With A490 & AW490 DC Condensing units.

Installation & Operators Manual.

12VDC (24VDC or 115/240VAC with optional converter)



Manufactured in Australia by:
Oze fridge Industries Pty Ltd.,
Yarroweyah, 3644 Victoria.
Phone: (61) 03 58732114
Email: oze fridge@ozemail.com.au
Web: www.ozefridge.com.au

Cruiser Services

Supplying the gear to let you go Cruising, Not Camping

OZEFRIDGE-USA
Marine Refrigeration



- | | |
|------------------------------------|----------------------------|
| 1: Sure-Thaw Controller. | 11: Pump supply terminals. |
| 2: Fault LED indicator. | 12: Temp Probe Terminals. |
| 3: On-Sleep switch. | 13: Condenser Fans |
| 4: Auto-Bypass switch. | 14: Mount holes under Fans |
| 5: ECO2 Power Manager | 15: Suction service valve |
| 6: Air/ Water switch. | 16: Suction connection |
| 7: Internal wiring Fuse. | 17: Suction valve cover. |
| 8:12V Power in & spike arrester. | 18: Liquid service valve. |
| 9A & 9B. Water Nipples. (AW490) | 19: Liquid line connection |
| 10: DC out. Cycles with compressor | 20: Liquid valve cover |



- | | |
|---|----------------------------------|
| A: Raise/ lower Buttons | F: Sleep / On switch |
| B: Compressor On / Off indicator. | G: Manual / Auto switch |
| C: Eutectic temperature read out. | H: ECO2 On / Normal (off) switch |
| D: Set button (Ignore other) | I: Pump + Hi/ Lo condenser speed |
| E: Fault indicator. See setting details, readouts etc., later in this manual. | |

NOTE: The grey twin cable running inside black insulation is a spare for powering a light or fan etc., if needed. (2 amp maximum)

Panel Control Read Out Set Up:

Press and hold the “SET” button until “E1” appears (about 6 seconds).

Press the “UP” or “DOWN” button to change.

Press the “SET” button to move to the next parameter.

Once all parameters have been set correctly, leave the buttons untouched and let the controller time out (about 6 seconds), the controller will automatically store new settings.

Parameter codes, recommended settings and meaning:

E1 = -25°C (lower set point limit)

E2 = 30°C (higher Set point limit)

E3 = 8 (hysteresis = difference between cut in and cut out temperature)

E4 = 1 (compressor start delay in minutes)

E5 = -3°C (eutectic temperature reading offset)

E6 = 0°C (condenser temperature reading offset)

F1 = 20 (max defrost duration in minutes) NOT APPLICABLE

F2 = 0 (defrost interval time in hours) NOT APPLICABLE

F3 = 20°C (defrost termination temperature) NOT APPLICABLE

F4 = 00 (display during defrost: 00=normal display, 01=last value before defrosting) NOT APPLICABLE

CF = °C (temperature unit of measure: °C- Celsius, °F= Fahrenheit)

Each system has a refrigeration unit, and the eutectic plate(s) packed in the shipping box. (Shipping box may also contain additional options: Water cooling pump kit, Remote panel, Spare components or other optional extras if applicable)

Take care dismantling packaging and avoid handling the eutectic plate by the black insulation covering that is housing the refrigeration lines, these lines can be damaged. (Some boxes have special unpacking instructions on the inside.)

POINTER:

Leave the black insulated lines coiled until you are ready to install the system. If the cabinet area is small, make a template of the eutectic plate mounting holes. Use the template to mark and prepare your mounting holes. It is usually best to locate the plate as high as possible within the cabinet box area.

POINTER:

The following tools will be required for the installation process:

- Material for marking a template / marking pen.
- 11mm wrench
- 16mm or 17mm open end wrench (depends on flare nut size)
- 19mm open end wrench
- 5mm Allen key
- Philips and blade screwdrivers.
- Line saddles and fixings for the eutectic plate to unit lines.
- Dish washing detergent for leak bubble testing. (Liquid)
- DC cable: (>2mt/6.5ft; 4mm²/#12) (>4mt/13ft; 6mm²/#10) >6mt/20ft; 10mm²/#8
- **Install a 15 amp fuse in-line near the DC *power supply source. (*Battery)**
- Eutectic plate stainless steel fixings. If the one supplied will not work for your layout.
- Silicon (non-acetic), Sikaflex or other sealant.
- Cleaning cloth
- **PINK** Eutectic solution (see page 6) **DON'T FOGET TO ADD TO PLATE(S)**

Pointer:

Plan how the lines should feed into and exit the cabinet box-where a >35mm/1 3/8" diameter hole can be installed on cabinet box wall. Prepare the refrigeration unit position and plan the line set run.

CAUTION:

Twin plate systems must remain relative to each other until the final mounting inside the cabinet box.

- 1: After establishing a cabinet box exit point for the line set, make a 35mm/1 3/8" hole.
 - 2: Insulate this hole inner diameter to prevent damage to the line set black insulation.
 - 3: With an assistant holding the eutectic plate(s), carefully unwind the lines.
 - 4: Feed the coupling end into the fridge / freezer and out through the 35mm/1 3/8" exit hole. (Do not remove caps at this point)
 - 5: Continue feeding the couplings and line set until they reach the condensing unit location, and the plate (plates) are also in position.
- It is best if the refrigeration lines don't rise greater than 1500mm/5' to the AW490 condenser.
- 6: Gently work the copper refrigerant lines, with thumbs in an outward manner to form bends. Don't bend or stress the lines near their ends.
 - 7: Fix plate(s) to the cabinet box wall, as high as possible.
 - 8: Locate condensing unit position and work lines toward their respective couplings.
- See below: (Color coded)
- 9: With the pipes *presenting horizontally to their respective couplings and sufficiently apart, they are now ready to connect. (*See picture below)

CAUTION:

*Covers with O rings, firm finger tight only.

Forward dust cover

*Do NOT connect copper pipes this side

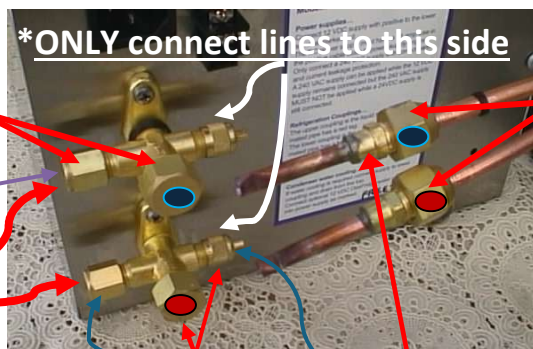

*Use wrench to tighten firmly.

- 10: Remove each service T valve's two dust covers. (Interchangeable covers)

Pointer:

(Keep the two caps to use if disconnecting later)

- 11: Next, the following steps should be completed continuously & quickly.
With a 16mm wrench holding the flare nut, remove the upper cap. (Some safe holding charge gas will escape as you remove cap). Quickly screw 'blue' flare nut onto the upper T valve with fingers then tighten with wrench.
- 12: When the wrench has tightened to firm add a quarter turn.

NOTE:

Caps /covers with 'O' rings should be firmly finger tightened only.

***Follow the instructions above and always refit cover-caps ASAP**

13: Next use the Allen key to fully open the upper service T valve counterclockwise until firm against the outer seat. Refit dust cover cap nut.

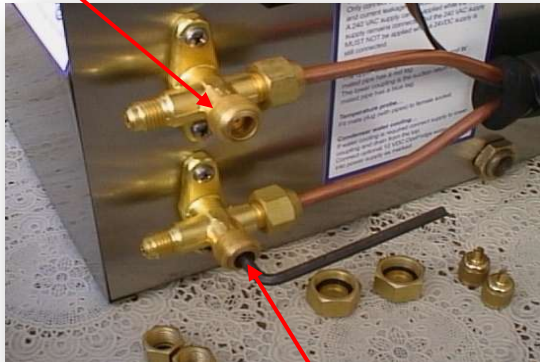

14: Now remove the caps from the lower flare nut, RED, fit flare nut to the lower service T valve and tighten with a wrench.

15: Use the Allen key to fully open this lower service T valve. RE-fit cover cap nut.

16: The condensing unit's refrigerant gas is now open to the entire system and ready to operate.

17: Now test for gas leakage by mixing dish wash detergent with an amount of water and use it to coat onto the couplings and dust caps. Do this in good light and watch for any very tiny bubbles. If present, tighten fittings slightly more.

18: Attach/anchor the insulated black line set to prevent line and coupling movement.

19: Connect a 12volt DC supply cable to the A490 or AW490's screw terminals 8. (See page 3 for cable sizes). The positive (red) connects to the RH (red) connector.

Connect the optional 115/240VAC converter power supply if this is to be utilized.

20: Connect the temp sender wires onto their terminals (Page 2 number 12)

21: Connect water pump supply line to the AW490 condenser inlet 8mm nipple if water cooling is being used. AW490: Connect pump power to terminals number 11. Only recycling water from a freshwater tank is advised. Do not use raw water (See page 11)

22: Now connect the other end of the 12volt DC supply cable to battery or power supply switch and you are ready for startup and fine-tuning...

POINTER:

Having the lines horizontally will make coupling easier. (See picture above). Line connecting flare nuts should spin on freely by hand initially and then tighten with wrench. NEVER use sealant or tape on the line connections.

POINTER:

To set up the Ozefridge system correctly it is best to first understand the basics of 'phase change, eutectics and the function of the Sure-Thaw monitoring and control system.
Process explanation:

When water changes from liquid to a solid (freezes) or when it thaws back into a liquid, it dissipates/absorbs more than eighty times the thermal energy that it required to alter the temperature up or down one degree while remaining as a liquid. (During phase change)

This change from a liquid to a solid or back to a liquid again is called 'phase change'. Simply: freeze – thaw – freeze – thaw – freeze etc.

Using this **latent heat** activity allows a large amount of thermal energy to be stored when the system is running, this stored energy is then available to maintain a constant cabinet box temperature when the condenser is in off cycle. Resulting factors = long run cycle and long off cycle.

The term 'eutectic solution' refers to the liquid used in the eutectic plate/s as a phase change medium.

If water was used as a eutectic solution, it would have a phase change temperature of approximately 0°C/32°F.

Note: All eutectic plate reservoirs are supplied dry, fill as follows:

To use the Ozefridge system in a cabinet box as a refrigerator requires a **eutectic solution to be added** with a phase change at approximately minus 5°C or 23°F.

(This relates to a mix of 10% PROPYLENE glycol (pink) with 90% pure water)

Using the Ozefridge system as a freezer requires a phase change at a point between minus 16°C to 20°C / 3°F to -4°F.

(This relates to 25% PROPYLENE glycol (pink) with 75% pure water) **solution.**

Eutectic Plate approximate Capacities:

Large 1.6" Thick Plate (Mix 3.0 qtrs.),	Large 2.4" Thick Plate (Mix 5.25 qtrs.)
Medium 1.6" Thick Plate (Mix 1.7 qtrs.),	Medium 2.4" Thick Plate (Mix 2.85 qtrs.)
Small 1.6" Thick Plate (Mix 1.16 qtrs.),	Small 2.4" Thick Plate (Mix 2.0 qtrs.)

Pointer:

Suggested eutectic mix to add to eutectic plate reservoir:

Start with a small container of *concentrated auto anti-freeze PROPYLENE glycol (pink radiator coolant, *approximately 100% glycol) then add clean water to provide the phase change blend ratio suggested above.

- 1: **First fill the eutectic reservoir** to within ***30mm/1 3/16"** of the top with a premixed eutectic solution. Refit plug loosely. (***40mm/1 1/2"** for portrait models)
- 2: Leave brass filler plug loose until plate(s) are frozen, then tighten.
- 3: Suggested mix should have a freeze point of approx. minus 6°c/42°f for a refrigerator and minus 18°c/-1°f for a freezer. The suggested medium starts with concentrated PROPYLENE glycol (pink) Available at an auto parts store. Suggested mix: See page 6.
- 4: Note that comparable products are slightly toxic (GREEN), please read their label before using. We recommend only using food grade of Glycol (PINK).
- 5: With the reservoir/s filled, connect and switch on the 12 VDC power supply.

Pointer: If the buzzer sounds, press any button on controller to eliminate.

- 6: Wait for the one minute controller delay at which time the unit should re-start. Or switch on manual (by-pass) for testing.
- 7: The system will run for several hours to obtain a freeze of solution initially.
- 8: Until fine-tuned, the system will be slow, draw excess current and may default often. Best results will occur once the initial start-up has been completed.
- 9: Initial running and tuning should be on DC power where possible, switched to On, Auto, ECO2 to OFF and if equipped with optional water cooling system connected and operative.

TUNING: (Turn ECO to OFF until fine tuning is completed)

- 1: If the screen temperature is well below 0°c/32°f and the upper T valve (BLUE) is ***frosting/icing up**, for a prolonged period before the required temperature is met, some reduction of the gas charge is needed. (***or icy-cold / wet while temperature is reading just below or above 0°c/32°f**)
- 2: ***To reduce gas charge**, first remove the top **forward dust cover cap** (Page4) from the upper service valves with the unit running, then depress the service valve stem for 3 to 4 seconds. Only purge if and when icing etc occurs. Reinstall dust caps!
- 3: Allow continued operation, if after another 15-20 minutes icing is still accumulating, keep repeating purge process. (Possibly several times)
- 4: Icing / cold sweating may sometimes occur when within 1 to 2 degrees of the required temperature being achieved - this is considered acceptable.
- 5: Ideally icing should be present on the blue line tag at the top of eutectic plate but not on the (blue) suction line or T valve area on side of unit, when the system is within a degree +/- of set cut-off temperature.

POINTER: Temporary icing/frosting can occur in rough sailing conditions.

CAUTION: ***Important note: The handling of R134a gas should be by a licensed tradespersons.**

Your system is factory pre-set as a freezer, please re-program as required.

These settings are:

To operate as a fridge set (SET) = -10C/14°f (Using 10% Glycol to 90% Water)

To operate as a freezer set (SET) = -22C/-8°f (Using 25% Glycol to 75% Water)

Adjustment later of (SET) up or down may be required to suit your needs.

The Four Switches. (Normally use all in Blue position.)

(1) Sleep/ On: To switch on or off. Sleep. (Manual will over-ride).

(2) Manual/Auto: Bypasses all controls including on / off switch and causes the unit to run continuously. Bypass can be used if to run continuously perhaps while loading or use as a manual back up if the controller system fails.

(3) ECO Off/ ECO On: Off allows normal control and function. ECO2 On provides power supply management as described below...

(4) Cond Lo/ Cond Hi + water: Lo allows the unit to operate as an air-cooled system only on 1X fan. Hi for adding the second fan and water cooling (AW490 model only).

ECO2 (Fitted internally to all A490 & AW490 models)

POINTER:

1: Switch to 'ECO2' for maximum efficiency / less power cycling will occur.

2: Turn ECO to Normalize (Off) when on long term shore power or when fine tuning.

NOTE:

1: Refrigeration is also induced at times when shore power is connected, reducing the demand later on battery storage by typically +40% or greater.

2: Whenever the DC supply rises above 13.3 volts (or 115/240VAC is detected) and the eutectic reservoir can take more freezing, the system will start. These functions are automatic with ECO2.

3: The ECO2 device also causes the eutectic mass to refreeze when DC power is abundant, keeping it within the colder 60% of the controllers' on-off settings.

4: Operating colder than minus 25C/-13°f can cause system stalling.

Fault Indicator LED. *Check voltage at unit while attempting to start.

The fault LED will indicate a problem with a sequence of flashes:

Flashes x 6 = *Controller/ electronic unit has a hardware failure.

Flashes x 5 = Thermal cut-out of electronic unit. (Check for faulty fan etc)

Flashes x 4 = Minimum motor speed error. (Very unlikely)

Flashes x 3 = *Motor start error. (Usually corrects itself. Leave running)

Flashes x 2 = Fan overload. (Faulty fan?.. replace)

Flashes x 1 = *Over or under voltage cut-off. (Voltage is <11.5 or > 17.0VDC)

NOTE:

1: The LED may indicate at times other than indicating faults, such as when on start delay, when the power supply is erratic or prior to fine tuning.

2: Blinking red LED Below frost symbol of controller=start delay, solid = run.

The Sure-Thaw controller is programmable to ensure that the Phase Change process operates correctly. (Cut off after eutectic freezes the on after thaw)



REFER BACK TO PAGE 2
PANEL READ OUT SETTING
SET UP (Celsius to Fahrenheit)

- 1: To change the selected Cut-Out (SET) temperature value, Press the Set button once, current cut out temp appears (blinking). Press "Up" or "Down" button to select desired temp.
- 2: Suggested cut-off settings are: To operate as a Fridge: SET= $-10^{\circ}\text{C}/-14^{\circ}\text{F}$
To operate as a freezer: SET = $-22^{\circ}\text{C}/-8^{\circ}\text{F}$.
- 3: The pre-set cut-in is always $8^{\circ}\text{C}/46^{\circ}\text{F}$ warmer than the SET cut-out setting. (8c=E3)

NOTE:

- 1: These settings will remain in memory and once set need not be changed unless a different temperature is required.
- 2: System will be on Start Delay for one minute. (Blinking red LED, top middle)
- 3: If alarm will sound when powered up. Press any button to stop sound.
- 4: To cancel Start Delay, press "Down" button.
- 5: Condenser temperature can be checked by pressing & holding "Up" button for 5s.
- 6: The fault indicator LED will indicate if the system detects a fault or is in Fail-safe' mode. (See page 8)

NOTE:

- 1: Compressor speed management and soft start is automatic.
- 2: The A490 & AW490 systems will start without any increase in current normally seen with electric motors and is almost silent when running.
- 3: The compressor will speed up in increments until it reaches the optimum speed for the job at hand.
- 4: If for any reason the system becomes overloaded, the compressor will slow to reduce the load. This usually will prevent overload cut-out which will only occur if the lower speed / load can't be safely maintained.
- 5: If a failsafe cut out occurs the unit will automatically attempt a restart every 60 Seconds until it can regain normal operations.
- 6: Top/Middle red LED system status: Flash=start delay Solid=run Off=off cycle

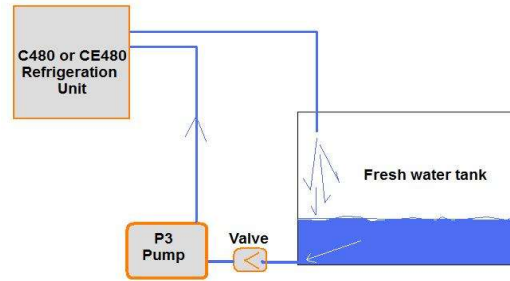

All Ozefridge **AW490** condensing units are supplied pre-equipped with a water cooled condenser, connecting nipples, isolation switch, fuse and terminals for pump power supply, ready for the addition of the P3 water cooling pump.

NOTE:

- 1: Condenser water cooling greatly improves system performance and power efficiency when ambient temperatures exceed 30°C/86°F (25°C/77°F when a freezer) or when the AW490 condensing unit is in a confined area with less air flow.
- 2: Water cooling is additional to the air cooling. AW490 can operate from either.
- 3: Don't twist the brass water nipples on the AW490 unit.
- 4: Smear silicon onto the unit nipples then slide the 8mm tubing on. Allow to set for 5 hrs before running the pump. You may have to use a heat gun to soften hose ends then use long nose pliers to expand allowing it to go over brass nipples. Hose clamps are not recommended.
- 6: The fuse (page 2, #7) provides protection for the pump circuit.
- 7: The AW490 has the unique Ozefridge 'Aqua-air' condenser and can operate as either an air cooled unit or water and air cooled. This coil is unique to the water cooled model and cannot be simply added to non-water cooled system.
- 8: The pump outlet should point upwards to reduce possible air cavitation.

POINTER:

- 1: To avoid corrosion and fouling, it is recommended that only water from the boat's freshwater tank be used. The cycling water is not harmed and the increase in tank water temperature is only 1° to 2° (30ltr or more) while the system is running, returning to normal soon after the cycle is completed.
- 2: The minimum effective tank storage is 30 litres.

INSTALL PUMP:

- 1: Locate the pump close to and below the freshwater tank.
- 2: Connect the thicker pump inlet (Suction) hose to the water tank outlet (or other outlet) with the check valve in this suction line. (Ensure the check valve is flowing in the correct direction!)
- 3: Then fit the thinner hose from pump outlet (Discharge) to the AW490's inlet nipple. (Avoid using hose clamps)
- 4: Connect a return hose from the AW490's outlet nipple back to the tank.
- 5: Connect the water pump wires to the 'Pump Supply' terminals. (Page 2 #11)

1: The 12VDC water pump will operate from a correct polarity power supply only therefore note colour coding. Connect to terminals 11 (+=RHS)

NOTE

Power is **only** supplied to the pump once the condenser temperature reaches +30°C/86°F and switches off once the temperature lowers to +20°C/68°F.

2: Only connect to the fuse protected terminals (# 11) on the side of the unit.

CAUTION:

The water cooling should be re-cycled fresh water from the boat's tank. If raw water is used, measures to eliminate electrolysis, corrosion and fouling must be used.

Damage caused by raw water use is not covered by warranty.

3: The pump is a quiet centrifugal type. (Not a self-priming type).

4: The P3 pump should be located below the water level with a check valve. If located above & with suction check valve, initial priming will be required.

5: The check valve locates between the pump inlet and water tank outlet.

6: Use a short piece of 8mm tube as a reducer for each side of the check valve.

7: Smear silicon over the 8mm brass nipples to ease the 8mm vinyl over. The food grade vinyl tubing will self-seal and usually doesn't require clamps.

8: Running for long periods without water may cause harm to the pump.

To operate:

Select '+Cond Hi' and whenever the AW490 runs and the condenser **temperature exceeds 30°C/86°F**, the pump will start and continue pumping as needed to maintain condenser efficiency. (Press 'up' button to read condensing temp)

NOTE:

If for any reason the water cooling system fails, the AW490 will continue to operate as an air cooled only system, reduced or slower cooling will occur.

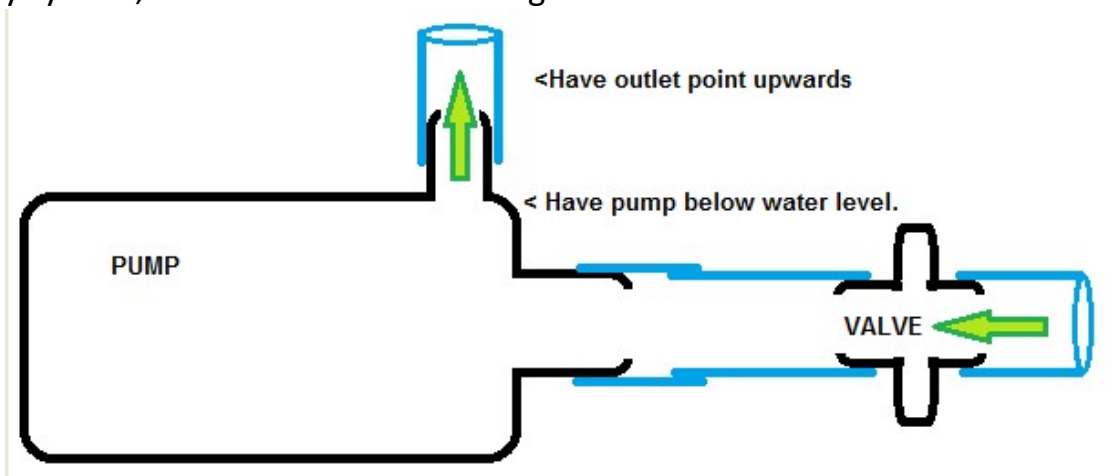

Q: I am ready to run my AW490 unit but don't have the water connected yet.

A: It can be run on DC but expect failsafe tripping and don't do any fine tuning of the gas charge until the water is connected and running.

Q: The system is running but stops occasionally.

A: The Ozefridge failsafe system protects against a range of harmful scenarios and does sometimes trip unnecessarily, especially until fine-tuned. (See page 7)

Q: I am not 100% sure of the 115/240 volt power supply available so is it safe to use.

A: Absolutely **not**. Only use 115/240 VAC from a reliable and properly grounded system supply.

We strongly recommend not using generators other than reputable brands.

Q: When I ordered, I didn't mention that it was to operate from 24VDC.

A: Contact Ozefridge before connecting to 24DC. You will need a converter available from Ozefridge.

Q: Is it ok to install the unit inside an enclosed cupboard or under a seat?

A: Yes, provided the water cooling is connected and operating. Otherwise, we suggest that two vents of at least 300cm²/23" (²) opening be provided to the enclosed area. One vent low down and preferably behind the unit adjacent to the air intake and the other high up in the enclosed area if possible.

Q: Can I duct the air away from the fan air exit area on top of the unit?

A: Yes, but the duct must be much larger than the fan area. We suggest at least 150mm diameter or similar. It is best to partition off between the front fan exit area and the air intake at the rear so that the warm air off the fan can't re-cycle.

Q: I have a single large vent where the unit is to go, is that sufficient?

A: No, air usually doesn't enter and exit the same hole. A flow through of air is required for proper ventilation, so a second vent properly located is essential.

Q: I need to run the wires through the walls to my remote controller's location.

A: Disconnect the multi- plug from the remote, run wiring through then re-couple the multi-plug. Contact Ozefridge if extension is required.

Q: I have been told that digital control systems can be affected by spikes!

A: True, also Motor Driver Modules but this system has a spike arrester fitted.

Q: Only 1X fan runs until the unit is getting quite warm on Cond-HI!

A: Like the water pump they are thermostatically controlled, switching second fan on at <30°C condenser temperature. (Press the up button to read condenser temperature) The second fan turns off again when the condenser cools to >20°C.

All refrigeration systems are heat pumps.

Efficient collection and disposal of this heat while restricting further heat from penetrating the insulated cabinet, is essential for a fridge to be effective.

Any 115/240AC power supply MUST be properly grounded and correctly wired. Suggest only using extension leads with moulded plug ends.

- 1:** Ensure that warm air exiting the fan area (front) can't return through the condenser at the rear. Isolate if necessary to prevent warm air recycling.
- 2:** Install the A490 or AW490 condensing unit in a dry, well-ventilated area.
- 3:** Locate the eutectic tank as high as possible in the cabinet to reduce stratification. (Unless temperature differences top to bottom is desired)
- 4:** A small circulation Fan will improve temperature spread throughout the cabinet if warm pockets occur. (Available from Ozefridge) Using the spare grey twin wires run with the piping, connect to terminals *8 on the unit for constant fan or *10 to allow the fan to cycle with the pump operation. (*See P2)
- 5:** Make sure that **both** high and low sides are evacuated if any future servicing is done and recharge with >160 grams of **only R134a** refrigerant. (>200g twins).
- 6:** Water cooling by recycling fresh water from the boats tank for most efficient refrigeration especially for tropical use. Water is NOT consumed or harmed.
- 7:** Raw sea water can be used but with the risk of electrolysis and fouling that can damage the system and will void the warranty. (Cupra nickel is used)
- 8:** The system has several failsafe functions to protect itself. These are self-resetting and may cause some confusion until the system settles down, is finetuned (P7) and you have become properly acquainted!
- 9:** Avoid vertical loops in pipe run. Horizontal is OK.
- 10:** A490 & AW490 systems are set for **12VDC operation**.
Contact Ozefridge first if 24VDC is to be used. (Unless ordered as a 24VDC unit)
- 11:** With either 12VDC or 115/240VAC converter connected, the unit knows to use the higher voltage when available. This is done automatically.
- 12:** Performance can be affected in rough sea conditions, especially twin plate systems. Do not alter anything as the system will return to normal operation.
- 13:** **NEVER** use **R134a dye, or pipe sealer, pastes or tape** on pipe connections.
- 14:** **INSIST** that any refrigeration mechanic working on this equipment reads this manual first, particularly the 'Repair & Service' supplement if servicing.

The contents of this manual are not offered or intended as advice.

Seek independent advice from others if needed.

First check: 'FRIDGE ASSIST' page at www.ozefridge.com

NOTE:

OzeFridge systems are used world-wide and often in extremely remote areas where tradespersons are sometimes incompetent or unavailable. We have restructured our products to make them user serviceable as possible, addressing the following here and assisted with phone/ email support.

- 1: Diagnosis of refrigeration system. (Gas charge etc)
- 2: Remedy for refrigeration problems.
- 3: Diagnosis of electrical system.
- 4: Remedy for electrical problems.
- 5: Performance expectation from correctly set-up system.
- 6: How to replace a faulty fan.
- 7: How to replace a faulty motor driver.
- 8: How to replace a faulty power converter.
- 9: How to replace a faulty remote controller with ECO2.

1: REFRIGERATION DIAGNOSIS

The refrigeration system extracts heat from the eutectic tank (evaporator) and disposes of it via the condenser.

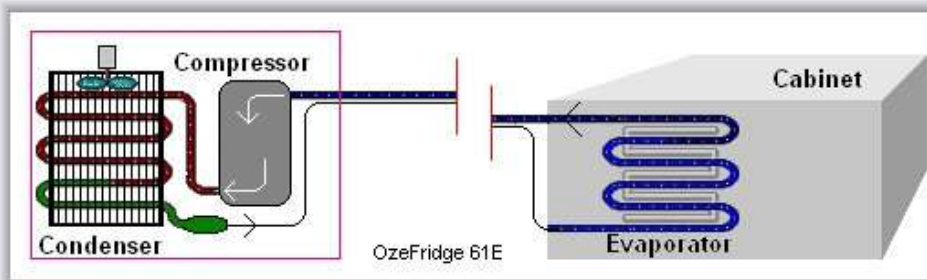

Assuming the power supply and other components are working correctly, then generally there are three refrigeration reasons why the system is not functioning.

They are: **A:** Loss of gas. **B:** Compressor failure. **C:** Refrigerant gas blockage.

POINTER:

(A is the most likely with B & C being quite rare)

A: Loss of R134a gas. Gas is only lost if the system has a gas leak. The OzeFridge system is entirely welded except for the brass coupling area; therefore, gas leaks are most likely in this area and often are indicated by oil wetting. The most likely signs of lost gas are slow cooling with the lower portion of the eutectic tank not frosting, low power consumption rate, low condenser temperature.

B: Faulty compressor. Compressor is mechanically stuck and requires replacing.

C: System can become blocked by contaminants due to unclean procedures during access since manufacture, or a gas leak has occurred.

2: REFRIGERATION REMEDY

A refrigeration mechanic would be required to confirm and repair the fault.

Initially the mechanic should only connect gauge / manifold hose to the suction (Upper blue) Schroder valve. The condenser temperature (therefore high side pressure) can be read by press & hold the "UP" button for 4sec on the controller.

The mechanic then should be able to identify the problem.

If repair and re-gas is needed then the system must be evacuated via both Schroder valves, then have a small amount of R134a (ONLY R134a) added to bring the system to positive pressure. The liquid line gauge hose must then be removed and the system run and charged via the suction line. Expect a suction of 15+ PSI (one+ bar) until the eutectic tank is well below zero when the suction pressure will also lower respectively. Expect just above zero PSI when at -22°C.

POINTER:

If gas has been lost, it is most likely that a leak has occurred because the coupling ¼ flare nuts are either not tight or over tightened to the extreme, or one of the cover nuts with 'O' rings has been over- tightened with a wrench.

3: ELECTRICAL DIAGNOSIS

The electrical supply system is where most problems occur, the most common of these being a bad power supply. Check voltage at the terminals on the A490 /AW490 both before and while running. A difference greater than half a volt before and after indicates a power supply line or battery problem.

The fault LED will indicate fault status as described on page 8 in this manual.

The Ozefridge controller panel has a manual bypass switch which eliminates the 'Sure-Thaw' digital temperature, ECO2 power management and speed control, allowing the system to run manually until switched back to "AUTO".

The other electronic components are fan, motor driver and power converter.

Using the bypass can often help identify if the problem is in the controller.

Likewise, if the system runs on 12VDC but not on the optional 115/240VAC then the power converter could be the problem.

If the faint sound of the motor attempting to start can be heard, then the motor driver may be faulty. Note the compressor is very quiet.

The fan and water pump should be running once the condenser temperature reaches <30°C/86°F. (off as it lowers to >20°C/28°F. Press/hold up button to read condensing temperature).

POINTER:

When changing power supplies or the unit is switched off then on again and the system is within its start- stop parameters, the system will not restart until it warms to the cut-in temperature which is the SET temperature plus 8°C. The soft start also has a delay of up to one minute.

SERVICE & REPAIR.. SUPPLEMENT (Continued) P3a

4: ELECTRICAL REMEDY

CAUTION:

Disconnect all power supplies BEFORE attempting any remedy.

6: Replacing a fan:

Remove the four 5mm stainless steel screws holding the top of the fans and grills. Remove the four 4mm SS screws from the canopy. Lift off canopy. Remove the lower four 5mm screws from the faulty fan(s) and replace. Plug fans into connectors and reassemble. Check that the fan label is outward and that nothing will foul the fan blades. Fans are type 240-25- 12VDC 4w (3 to 5w is ok)



8: Install / Replace the optional 240 VAC to 12 VDC power converter:



<< IMPORTANT:
With optional AC-DC converter.

12VDC battery power **MUST** only be connected to the terminals on the black relay box. **NOT to terminals 8.** (Positive + to RHS.)

The red and black wires from the black relay box connect to terminals 8.

Usually, the 240VAC converter is pre-installed otherwise fit as above or in a safe remote location. Leave both 240VAC and 12VDC supplies connected and the converter will automatically use the higher voltage whenever available.

POINTER:

This sealed converter has been reconstructed to suit the Ozefridge system **and must not** be connected in any other way or to any other equipment.

Replacing the Motor Driver Module: DISCONNECT POWER SUPPLY FIRST

Remove the eight screws (4 top & 4 fan top rows). This frees up the cover from the fans. Then remove fans by removing the bottom screws. The fans and cover have enough cable to allow them to be drawn away from the unit for access.

Loosen the screw securing the MDM by 2 turns Anti-Clockwise. (don't remove) With the wall pushed over to the left on an angle, pivot the driver clockwise to 'un-lug' it from the rear. Ease the MDM plug squarely off from the compressor.

To refit, press the compressor plug on firmly then with the driver at an angle to its final position, locate the rear of the driver then hinge counterclockwise into position and tighten holding screw. Refit coupling to the new driver. Refit fans and cover and test run. Terminals are connected by a sealed coupling. See below

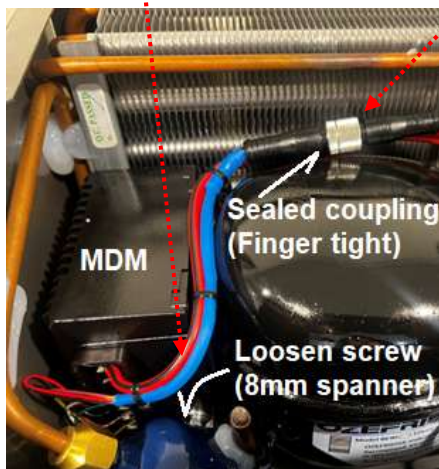

Electrical connection to the MDM and Control panel is via water proof screw together sockets and plugs.



No spade connectors are used or recommended

POINTER: Make sure the rear of the MDM is properly 'lugged'. It should not feel loose when the locating screw is tightened.

Odd readings on LED!

Displaying **LL** or **44** indicates an open temperature probe circuit. The temp probe circuit runs from the A490 /AW490 terminals 12, along inside the black insulation then to a sensor located in the *eutectic tank. (*Where 3mm Diameter black wire enters). Use a multi-meter to read the resistance of the disconnected wires. If it is between 5kΩ and 50kΩ the circuit to the eutectic plate and sensor is OK.

If **HH** appears the unit is overheating. Check fans and water cooling.

The unit has auto shut down if the temperature reaches 55C (And auto resetting)



TECHNICIAN PLEASE READ because Micro Systems can be easily damaged

- We know that refrigeration technicians are expected to service and repair a vast range of different equipment from micro systems like this tiny Ozefridge through to massive multi-ton installations, and it is near impossible to be up to date with them all.
- At Ozefridge, as refrigeration manufacturers whose staff are all from the service industry also, we understand this and are available seven days a week for support. As simple as making a phone call if you need us.
- We are lucky, we designed, engineered and manufacture the Ozefridge systems only, so we focus on this one product only and know it well.

Tips for the Technician:

- Air in these tiny systems is critical. If in doubt replace the 032 flared filter dryer, evacuate and re-gas. ONLY use pure R134a nothing else!
- Only liquid charge via suction but not exceeding 15-20 psi. Too much liquid at once or over charge can destroy the compressor
- Any gas leak will most likely be either the flare nuts not tight enough or one of the four O rings is either missing or has been over tightened
- Always open valves hard against their outer seats then fit cover nut.
- Expect the system to operate similar to a domestic fridge or freezer. Expect a suction of approx. 15 psi after starting up reducing to 6-8 psi at -10° readout and near zero as you near -22°c (freezer)
- Avoid fitting a gauge hose to the liquid line valve (red) as removing it later will alter the charge as some liquid refrigerant will be lost.
- To read the high side press and hold the up button. This will give the condenser temperature and can be related to high side pressure.
- Note, the 2X fans (and pump AW490 model) will only come on once the condenser temperature reads <30°c, one drops off if it reduces to >20°c.
- Operating normally expects a power consumption rate of 5.5 to 7.0 Amps with a 'just warm feel to the red liquid coupling and cool for the suction.
- The blue patch on the suction line at the top of the eutectic plate is a good point to check for evaporation and therefore adequate gas.
- The red LED in the top middle of the controller indicates: Flashing=start delay, solid= cooling cycle, off= thawing cycle. (Ignore others)
- **NEVER.. use any sealants or seal tapes etc., on this system.**
- **NEVER.. connect dry nitrogen for testing unless properly regulated.**

***Important note:** Some countries including Australia, require that R134a gas should only handled by licensed tradespersons.

1: SYSTEM SPECIFICATIONS: (Please read, micro systems are easily damaged)

- **Refrigerant:** Pure R134a ONLY. Do not use substitutes or additives.
- **Refrigerant charge:** From evacuation add 160 grams for single eutectic plate systems and 200 for twins.
- **Evacuation:** If evacuating the system, a two stage vacuum pump coupled to BOTH high and low side Schroeder valves must be used.
- **Recharging:** When re-gassing refrigerant should be added slowly as liquid via the suction Schroeder valve until the system pressure is just above zero. Remove high side gauge hose from system. Start system. Next with the system now running, slowly bleed in R134a liquid but do not exceed a suction pressure of one bar (approx. 15 PSI). Continue until the measured amount has been charged or until 15 PSI suction pressure is constant without further refrigerant being added.
- **Compressor oil:** The system contains 140 cc of POE oil.
- **Compressor:** Ozefridge Model BE90. Three phase 12VDC motor with six stage soft start and built-in failsafe protection.
- **Compressor Performance Data:** (At preset speed)
Capacity (CECOMAF) 87.4 Watt (-20c)
Power Consumption: 82.2 Watt. COP (CECOMAF) 1.07
- **Condenser:** A490: Ozefridge 18-18-3 Triple pass refrigerant.
- **Condenser:** AW490: Ozefridge 18-18-3w Triple-pass refrigerant & water.
- **Condenser fans:** Type 120-120-25 0.38a 12VDC. (0.25a to 0.4a is ok)
- **Controller:** SF-102s sealed digital 12VDC. Twin relay/ sensor
- **Controller sensor:** Thermistor with resistance between 5K & 50k ohms.
- **Control sensor location:** One inside eutectic plate, other on condenser.
- **Control Panel:** SS with Ozefridge PCB16 loaded.
- **Capillary:** 0.8mm ID (key ind)
- **Capillary locale:** From ¼" liquid line to ¼" evaporator line. Both external.
- **Filter-dryer:** Type 032 solid core ¼" flared (Mounted behind fans)
- **Accumulator:** None
- **ECO2:** Ozefridge integrated voltage monitor to PCB.
- **Couplings:** Brass 3 way ¼" with Schroeder fitting & 5mm Allan key closer.
- **Eutectic Plate:** Ozefridge fabricated 318 ss with 4mm ss bolts.
- **Eutectic evaporator:** Continuous 3/8" copper top entry cascading down.
- **Water pump:** (AW490) Topsflo 12VDC centrifugal. 8 & 10mm nipples.
- **Control Circuit Fuse (not DC supply fuse):** Type 20-5 rated at 5.0amp.

Power connections.

Left: Connecting to 12vdc power supply. (Top left)
And below with optional 240VAC converter.

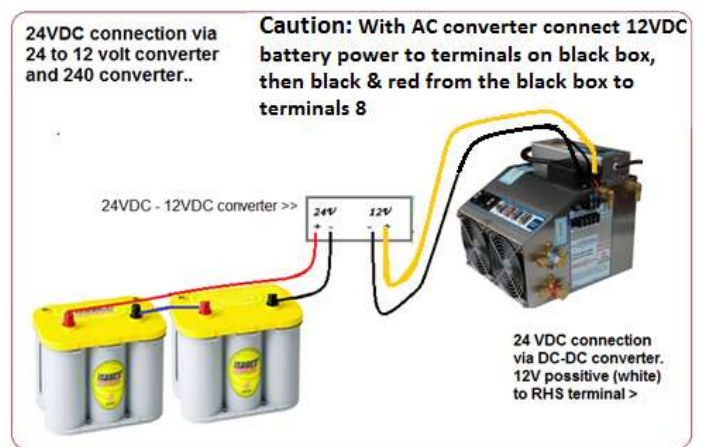
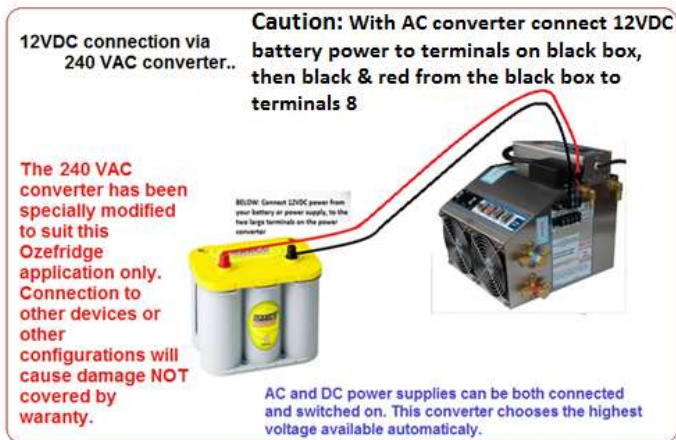
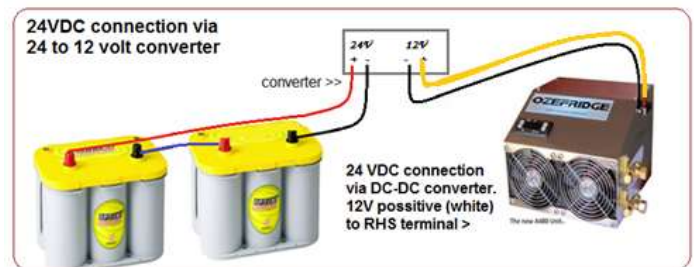
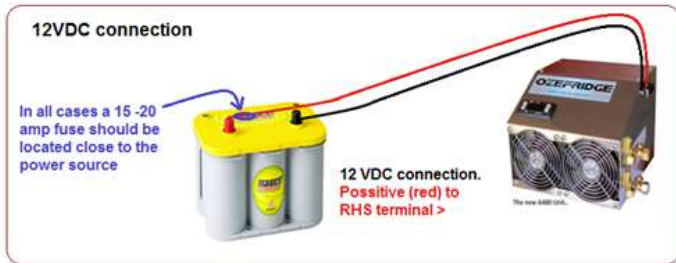

Right: Connect to 24VDC supply. (Top right)
And below right with optional 115/240VAC converter.

A spike arrester is fitted to the 12VDC power in terminals to protect the system. >>

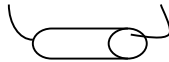

For further assistance with technical issues, check our 'Fridge Assist' page at our website: <https://www.ozefridge.com/technical-data>

Added Information:

As a manufacturer of DC refrigeration systems, we and others in the industry have known for a long time that the vast majority of service issues are power supply related and not a fault of the refrigerator or refrigeration system.

This power supply failure is often difficult to convey - the voltage on the ship's voltage meter may indicate that all is well.

It is ONLY the voltage at the fridge unit and ONLY while it is running, or attempting to start, that the voltage is relevant.

Voltage without load is not an accurate measure.

Something new!

Modern technology has now provided us with a tiny, digital voltmeter that can read voltage at the unit where it matters! This meter will now be fitted standard to all Ozefridge systems as shown below.



Testing for voltage drop causing compressor to fail at start-up may be identified by this meter but will still need to be confirmed as described at our 'Fridge Assist' page using a digital multi meter.

<https://www.ozefridge.com/technical-data>

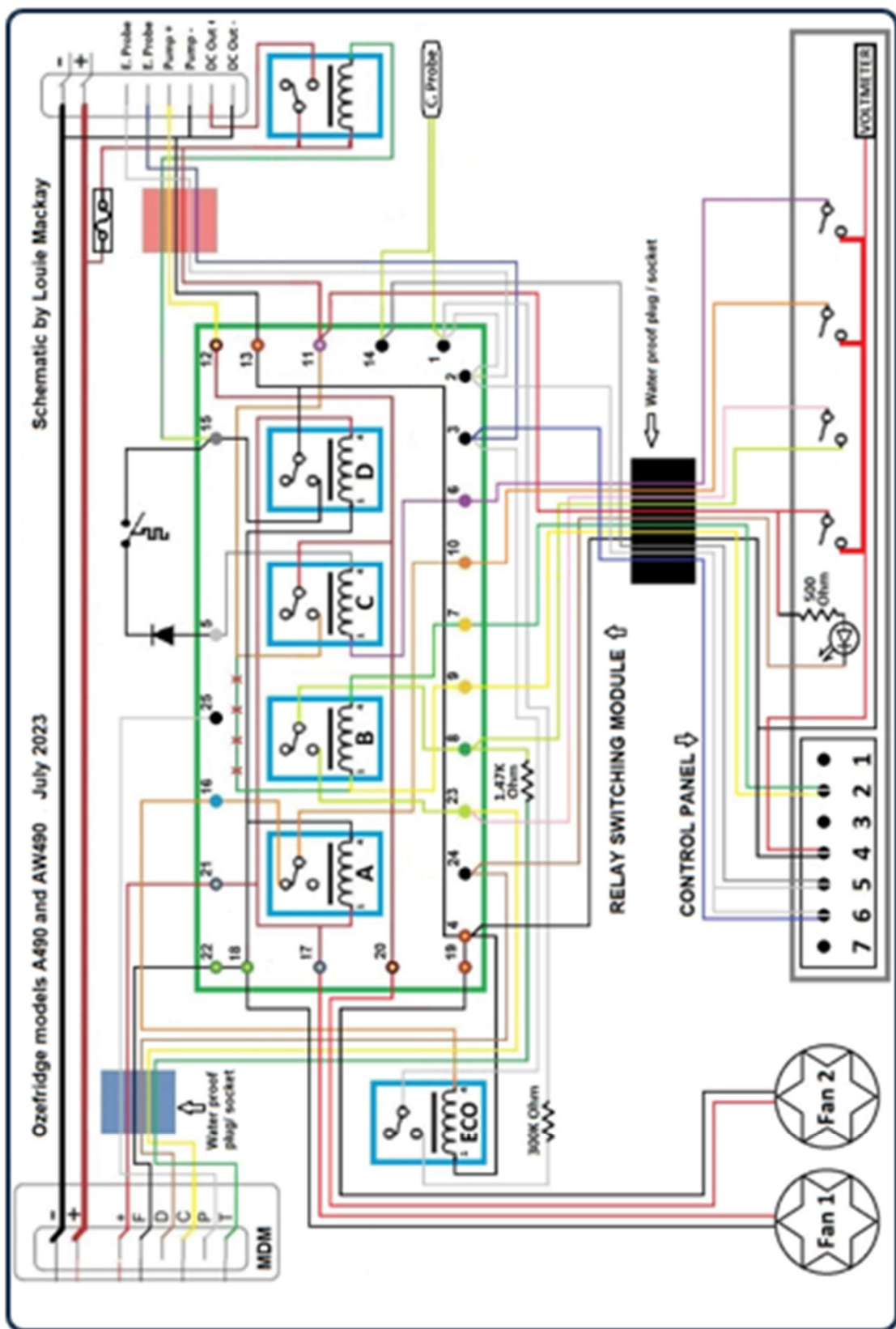

Note: Diagram above is subject to change.